

Advertisement requirements 2009

Terms and conditions

Page 2

- Deadline dates**
- Cancellations**
- Position**
- Alterations**
- Variations in colour**
- Advertising agencies**
- Advertisement material archive**
- Payment**

How to get your digital material to us

Page 3

Advertisement specifications

Double page spread (DPS)	4
Full page	5
Half page VERTICAL	6
Third page VERTICAL	7
Half page HORIZONTAL	8
Third page HORIZONTAL	9
Quarter page VERTICAL	10
Quarter page HORIZONTAL	11
Strip	12
Directory advertisement sizes	13
E-mail bulletin advertisement	14

Basic problems with advertisement material explained

The difference between a bleed and a floating advertisement	15
No bleed	15
Text too close to the cutting edge	15
RGB files	16
Bitmapping/Pixelating/Low resolution	16

Who can make up my advertisement material?

Page 17

Brooke Patrick Studio

Terms and conditions

Deadline dates

Booking deadline

1st day of the month prior to the month of publication.

Material deadline

5th day of the month prior to the month of publication.

- In the event that material does not reach us on time as instructed on the advertisement confirmation letter, Brooke Patrick Publications reserves the right to repeat old material, or to charge the client for the advertisement without it appearing, or to place the advertisement in a future edition of the same magazine.

Cancellations

- Cancellations will only be accepted in writing (with the onus of proof resting with the advertiser) and received by no later than the 1st of the month prior to the month of publication. If any advertisements are cancelled and not replaced during the course of the contract, a surcharge must be made in accordance with our rate card.

Position

- No position can be guaranteed unless the advertiser has paid a surcharge or if it is a special position.

Alterations

- Standard production rates apply for any additional work required to make digital work press-ready, including re-sizing advertisements and adding crop-marks.
- Alterations are subject to a fee (see page 17).

Variations in colour

- Brooke Patrick Publications accepts no responsibility for slight variations in colour on advertisements.
- Brooke Patrick Publications accepts no responsibility for colour variations in advertisements that are supplied without a colour correct proof.

Advertising agencies

- Should an advertising agency be contracted to manage direct bookings, the value of the initial booking may not be reduced.
- Agencies forfeit a portion of commission if payment is not received within 45 days of the invoice date, and all commissions after 60 days.

Advertisement material archive

- Advertisement material must be supplied in digital format, as stipulated, and will be kept in the advertisement material archive for a period of no longer than six months from the date of that material's final insertion.

Payment

- Payment for advertisements is strictly 30 days from the invoice date.

How to get your material to us

Deadline dates

Material deadline

We must receive your material no later than the 5th day of the month prior to the month of publication.
You are welcome to send your material earlier.

- In the event that material does not reach us on time, as instructed on the advertisement confirmation letter, Brooke Patrick Publications reserves the right to repeat old material, or to charge the client for the advertisement without it appearing, or to place the advertisement in a future edition of the same magazine.

Options available for sending material to us:

E-mail
Websend
Delivery/Courier
Post

E-mail address

dtp@brookepatrick.co.za

Websend

You can contact websend for more information:

<http://www.websend.co.za/websend/>

Paolo Aceto (IT manager/technical support on newspapers and magazines)

Cell: 082 339 5832

paolo@wsd.co.za

Physical address

Building #13
Pinewood Office Park
33 Riley Road
Woodmead
Johannesburg

Postal address

Private Bag X40
Rivonia
2128

Advertisement specifications

- Files can be supplied on **CD, DVD, websend** or via **e-mail** (e-mail file not exceeding 8 MB).
- Advertisements can be e-mailed to **ntp@brookepatrick.co.za**

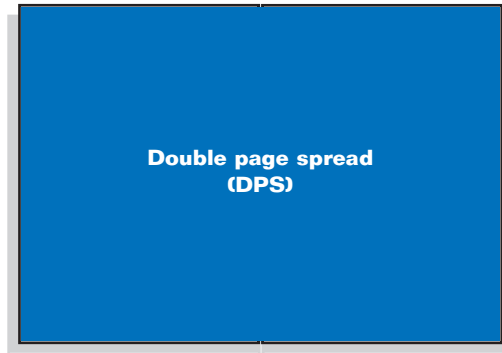

Magazine advertisement

DPS

LANDSCAPE

420 mm x 297 mm

Booking Deadline
1st day of the month prior to the month of publication.

Material Deadline
5th day of the month prior to the month of publication.

BROOKE PATTRICK
P U B L I C A T I O N S

Bleed advertisement

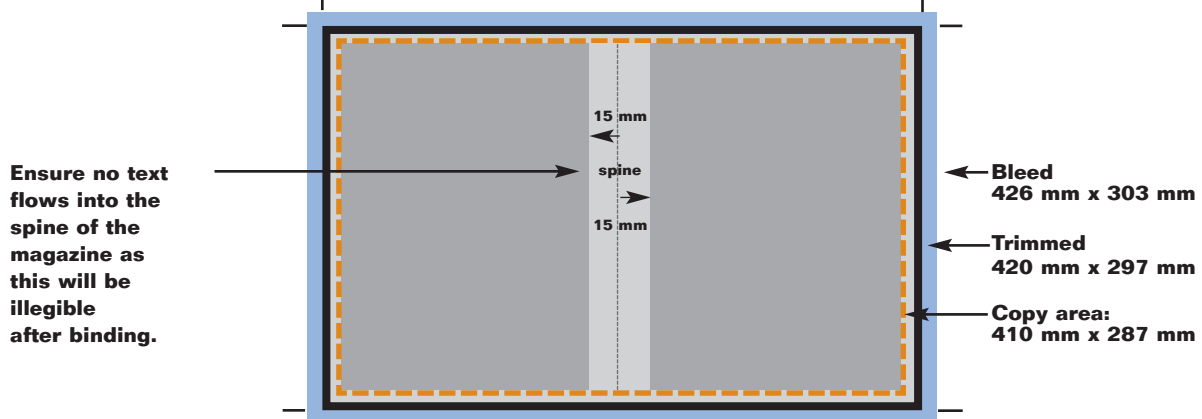

“Floating” advertisement

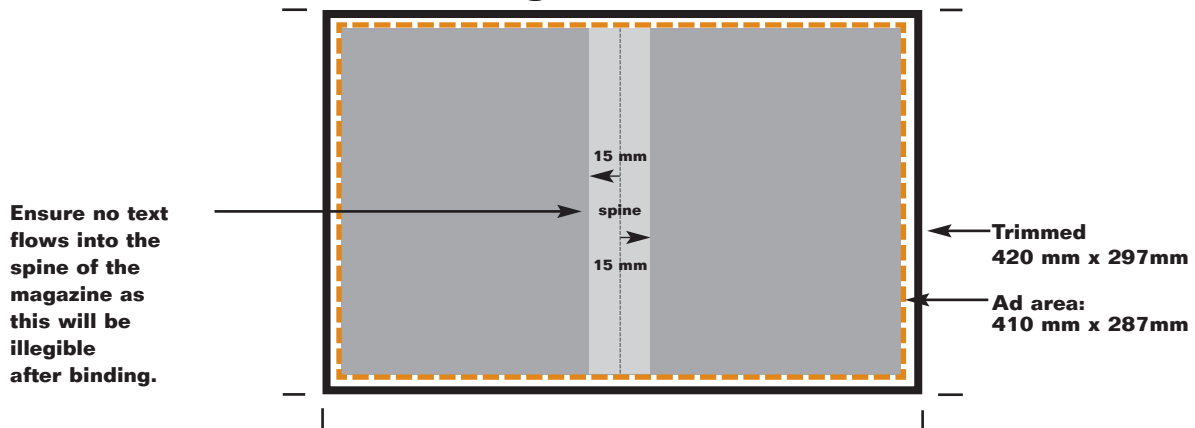

Reproduction material

- **Digital files required** - **PDF** (Closed, all fonts included, press-optimised PDF file, PDF/X-1a:2001)
- **Tiff** (300 dpi Tiff (CMYK, real advertisement size)
- **JPG** (300 dpi JPG, highest quality (CMYK, real advertisement size)

Brooke Patrick Publications can ONLY accept these three file types.

- **Crop marks**

All digital files must be supplied with crop marks. Crop marks must show the trim size.

A conversion rate of R350 will be applicable if the advertisements must be re-sized or are supplied without crop marks.

- **Bleed**

All files must have 3 mm bleed.

- **Colour proof**

A colour proof of the advertisement must be submitted. Brooke Patrick Publications accepts no responsibility for colour variations in advertisements that are supplied without a colour correct proof.

Advertisement specifications

- Files can be supplied on **CD, DVD, websend** or via **e-mail** (e-mail file not exceeding 8 MB).
- Advertisements can be e-mailed to **dtp@brookepatrick.co.za**

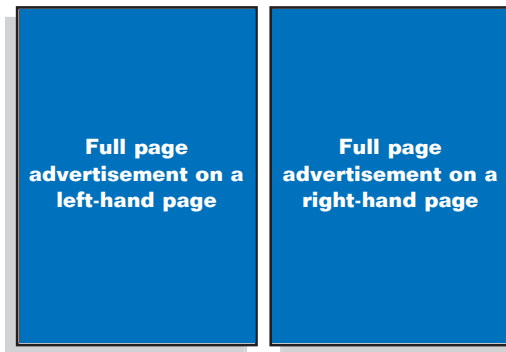

Magazine advertisement

Full page

PORTRAIT

210 mm x 297 mm

Booking Deadline
1st day of the month prior to the month of publication.

Material Deadline
5th day of the month prior to the month of publication.

BROOKE PATTRICK
P U B L I C A T I O N S

Bleed advertisement

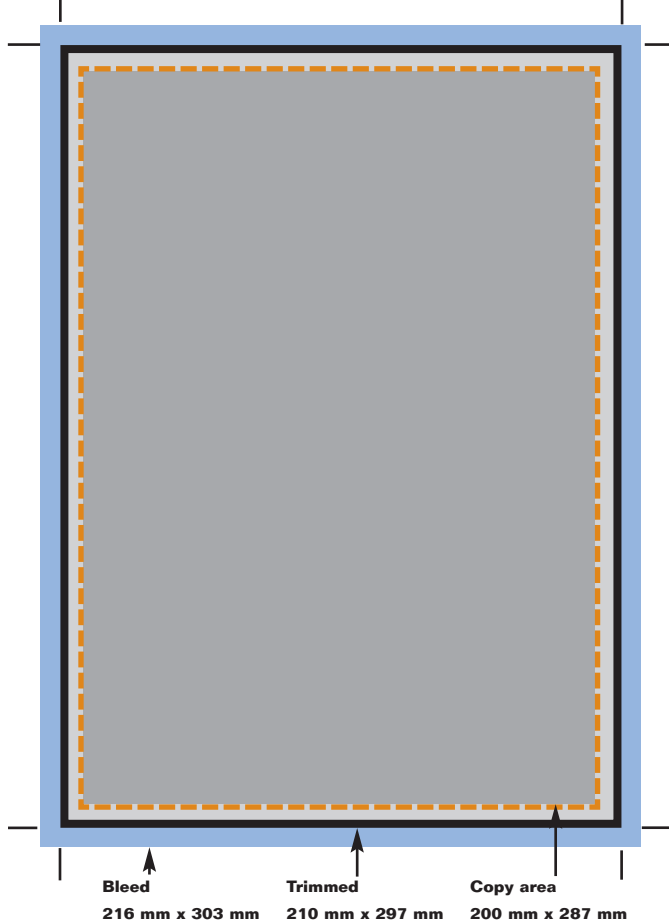

“Floating” advertisement

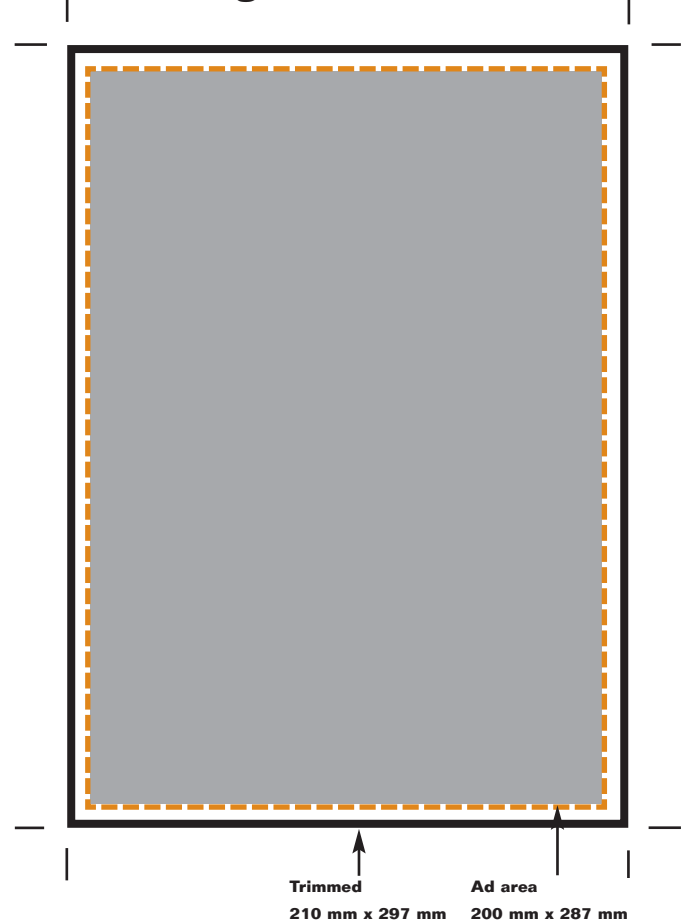

Reproduction material

- Digital files required** - **PDF** (Closed, all fonts included, press-optimised PDF file, PDF/X-1a:2001)
- **Tiff** (300 dpi Tiff (CMYK, real advertisement size)
- **JPG** (300 dpi JPG, highest quality (CMYK, real advertisement size)

Brooke Patrick Publications can ONLY accept these three file types.

- Crop marks**

All digital files must be supplied with crop marks. Crop marks must show the trim size.

A conversion rate of R350 will be applicable if the advertisements must be re-sized or are supplied without crop marks.

- Bleed**

All files must have 3 mm bleed.

- Colour proof**

A colour proof of the advertisement must be submitted. Brooke Patrick Publications accepts no responsibility for colour variations in advertisements that are supplied without a colour correct proof.

Advertisement specifications

- Files can be supplied on **CD, DVD, websend** or via **e-mail** (e-mail file not exceeding 8 MB).
- Advertisements can be e-mailed to **dtp@brookepatrick.co.za**

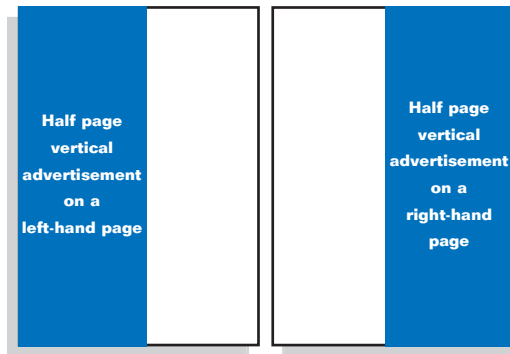

Magazine advertisement

Half page

VERTICAL

297 mm x 100 mm

Booking Deadline

1st day of the month prior to the month of publication.

Material Deadline

5th day of the month prior to the month of publication.

BROOKEPATTRICK
P U B L I C A T I O N S

Bleed advertisement

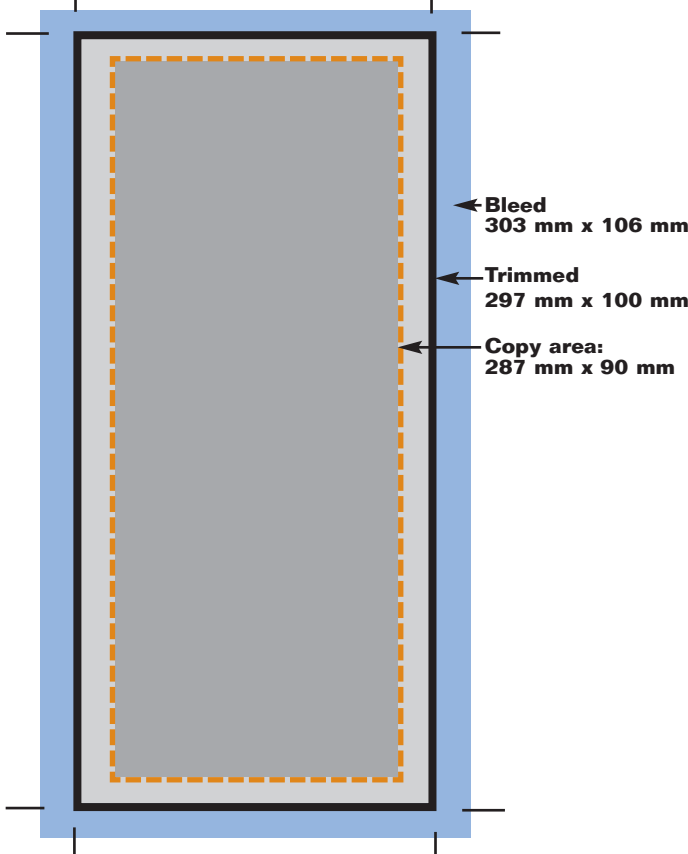

“Floating” advertisement

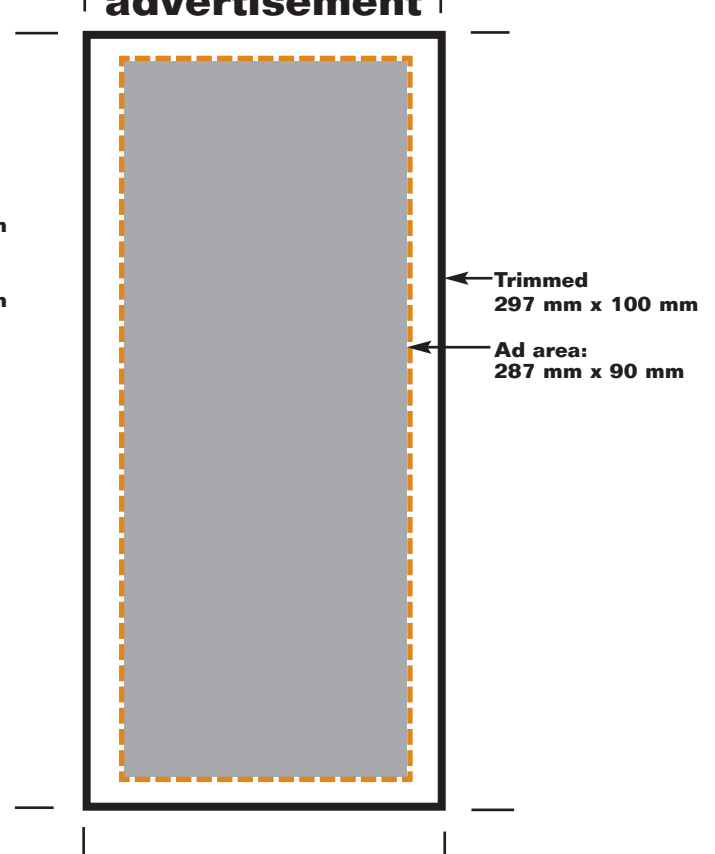

Reproduction material

- **Digital files required** - **PDF** (Closed, all fonts included, press-optimised PDF file, PDF/X-1a:2001)
- **Tiff** (300 dpi Tiff (CMYK, real advertisement size)
- **JPG** (300 dpi JPG, highest quality (CMYK, real advertisement size)

Brooke Patrick Publications can ONLY accept these three file types.

- **Crop marks**

All digital files must be supplied with crop marks. Crop marks must show the trim size.

A conversion rate of R350 will be applicable if the advertisements must be re-sized or are supplied without crop marks.

- **Bleed**

All files must have 3 mm bleed.

- **Colour proof**

A colour proof of the advertisement must be submitted. Brooke Patrick Publications accepts no responsibility for colour variations in advertisements that are supplied without a colour correct proof.

Advertisement specifications

- Files can be supplied on **CD, DVD, websend** or via **e-mail** (e-mail file not exceeding 8 MB).
- Advertisements can be e-mailed to **ntp@brookepatrick.co.za**

BROOKE PATTRICK
P U B L I C A T I O N S

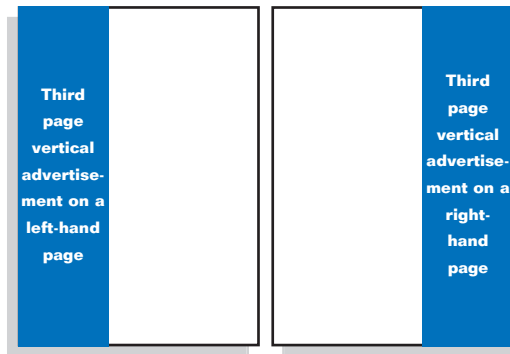

Magazine advertisement

Third page

VERTICAL

297 mm x 65 mm

Booking Deadline

1st day of the month prior to the month of publication.

Material Deadline

5th day of the month prior to the month of publication.

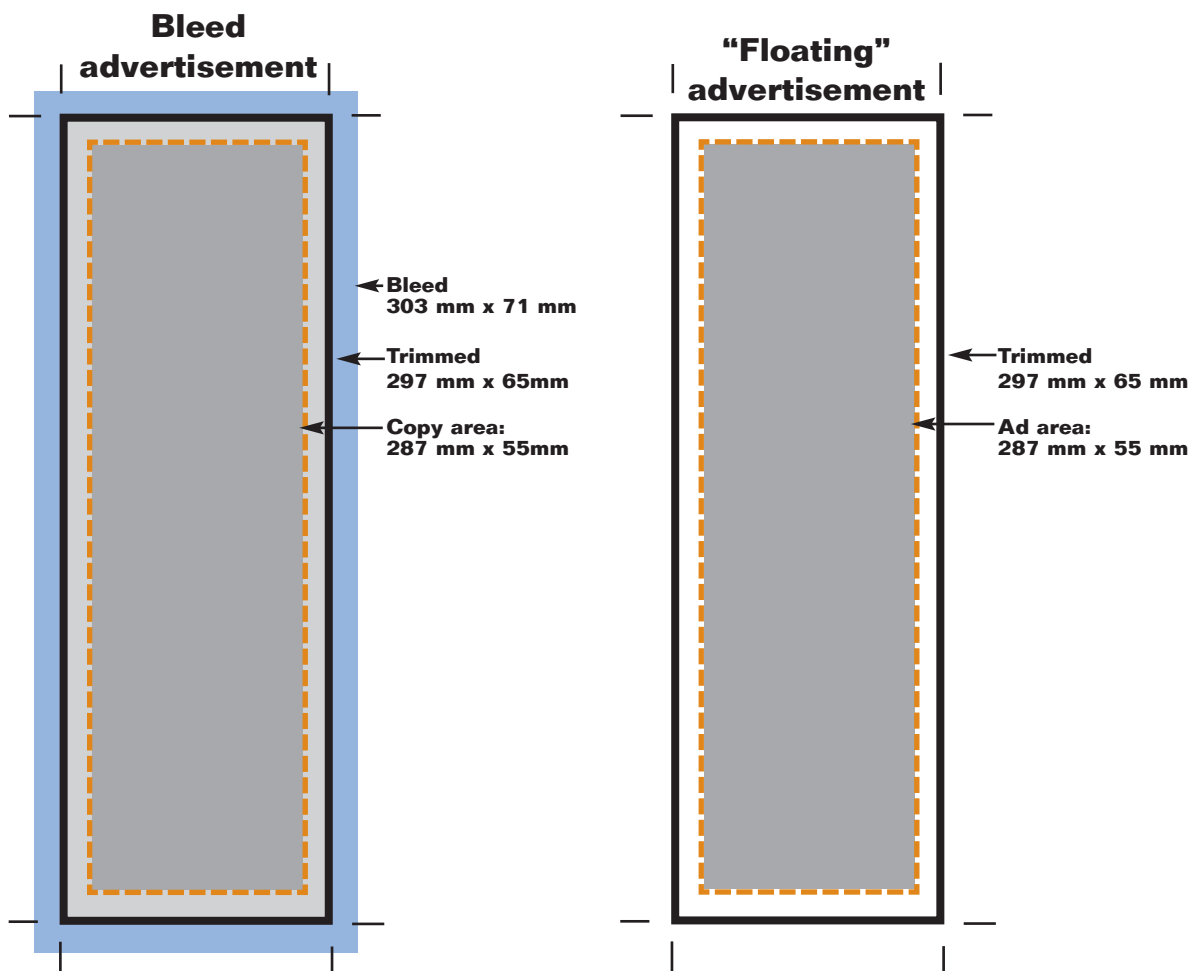

Reproduction material

- **Digital files required** - **PDF** (Closed, all fonts included, press-optimised PDF file, PDF/X-1a:2001)
 - **Tiff** (300 dpi Tiff (CMYK, real advertisement size)
 - **JPG** (300 dpi JPG, highest quality (CMYK, real advertisement size)

Brooke Patrick Publications can ONLY accept these three file types.

- **Crop marks**

All digital files must be supplied with crop marks. Crop marks must show the trim size.

A conversion rate of R350 will be applicable if the advertisements must be re-sized or are supplied without crop marks.

- **Bleed**

All files must have 3 mm bleed.

- **Colour proof**

A colour proof of the advertisement must be submitted. Brooke Patrick Publications accepts no responsibility for colour variations in advertisements that are supplied without a colour correct proof.

Advertisement specifications

- Files can be supplied on **CD, DVD, websend** or via **e-mail** (e-mail file not exceeding 8 MB).
- Advertisements can be e-mailed to **ntp@brookepatrick.co.za**

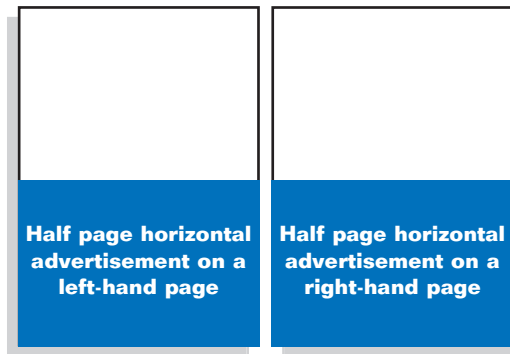

BROOKEPATTRICK
P U B L I C A T I O N S

Magazine advertisement

Half page

HORIZONTAL

140 mm x 210 mm

Booking Deadline

1st day of the month prior to the month of publication.

Material Deadline

5th day of the month prior to the month of publication.

Bleed advertisement

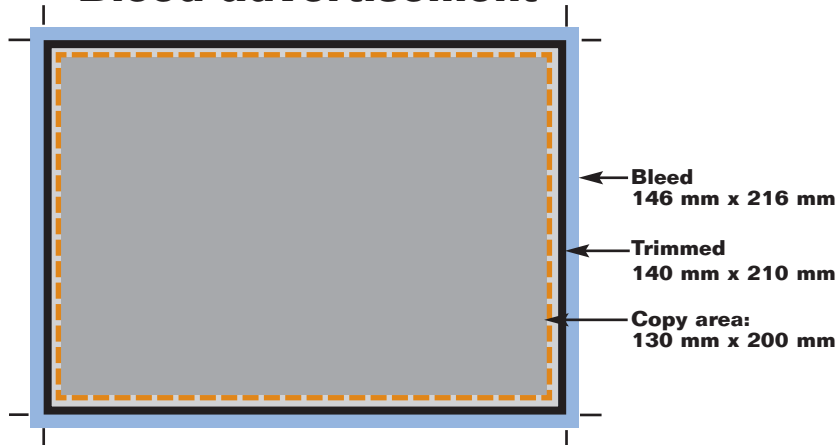

“Floating” advertisement

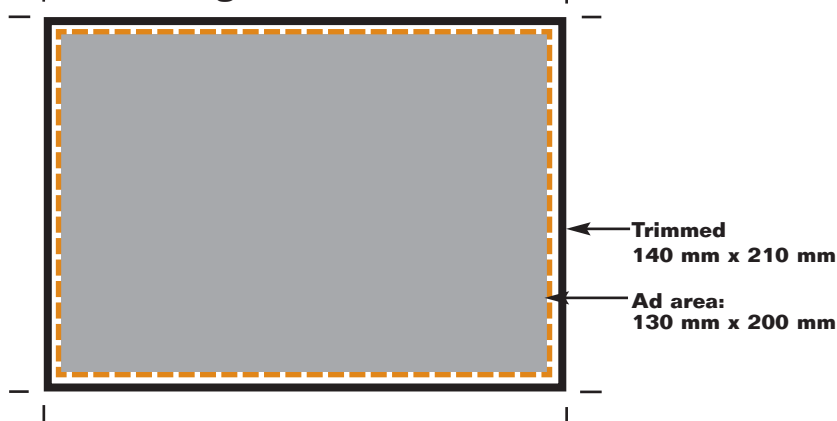

Reproduction material

- **Digital files required** - **PDF** (Closed, all fonts included, press-optimised PDF file, PDF/X-1a:2001)
- **Tiff** (300 dpi Tiff (CMYK, real advertisement size)
- **JPG** (300 dpi JPG, highest quality (CMYK, real advertisement size)

Brooke Patrick Publications can ONLY accept these three file types.

- **Crop marks**

All digital files must be supplied with crop marks. Crop marks must show the trim size.

A conversion rate of R350 will be applicable if the advertisements must be re-sized or are supplied without crop marks.

- **Bleed**

All files must have 3 mm bleed.

- **Colour proof**

A colour proof of the advertisement must be submitted. Brooke Patrick Publications accepts no responsibility for colour variations in advertisements that are supplied without a colour correct proof.

Advertisement specifications

- Files can be supplied on **CD, DVD, websend** or via **e-mail** (e-mail file not exceeding 8 MB).
- Advertisements can be e-mailed to **dtp@brookepatrick.co.za**

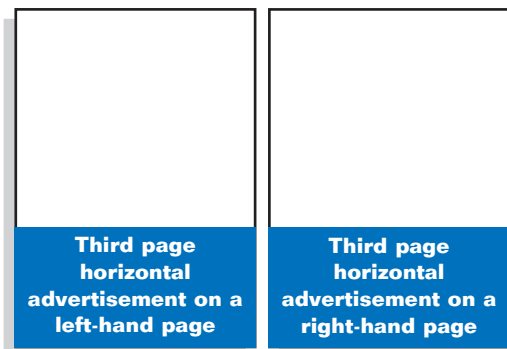

BROOKEPATTRICK
P U B L I C A T I O N S

Magazine advertisement

Third page

HORIZONTAL

95 mm x 210 mm

Booking Deadline

1st day of the month prior to the month of publication.

Material Deadline

5th day of the month prior to the month of publication.

Bleed advertisement

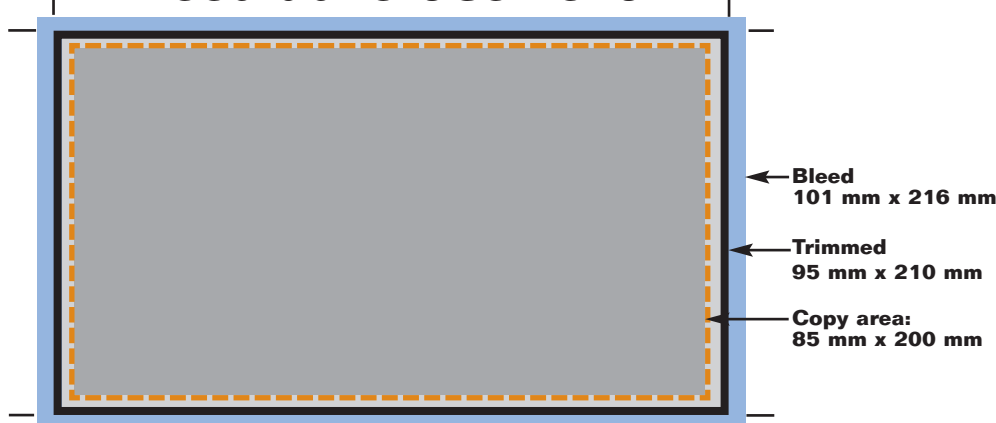

“Floating” advertisement

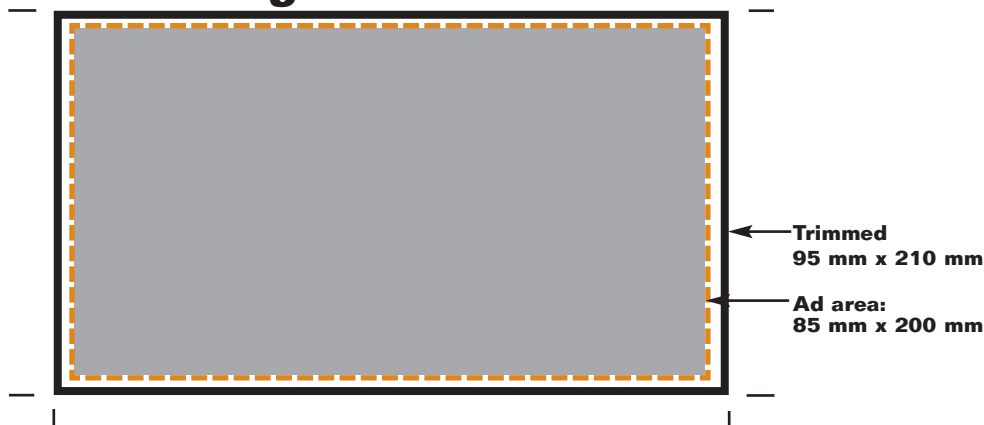

Reproduction material

- **Digital files required** - **PDF** (Closed, all fonts included, press-optimised PDF file, PDF/X-1a:2001)
 - **Tiff** (300 dpi Tiff (CMYK, real advertisement size)
 - **JPG** (300 dpi JPG, highest quality (CMYK, real advertisement size)

Brooke Patrick Publications can ONLY accept these three file types.

- **Crop marks**

All digital files must be supplied with crop marks. Crop marks must show the trim size.

A conversion rate of R350 will be applicable if the advertisements must be re-sized or are supplied without crop marks.

- **Bleed**

All files must have 3 mm bleed.

- **Colour proof**

A colour proof of the advertisement must be submitted. Brooke Patrick Publications accepts no responsibility for colour variations in advertisements that are supplied without a colour correct proof.

Advertisement specifications

- Files can be supplied on **CD, DVD, websend** or via **e-mail** (e-mail file not exceeding 8 MB).
- Advertisements can be e-mailed to **ntp@brookepatrick.co.za**

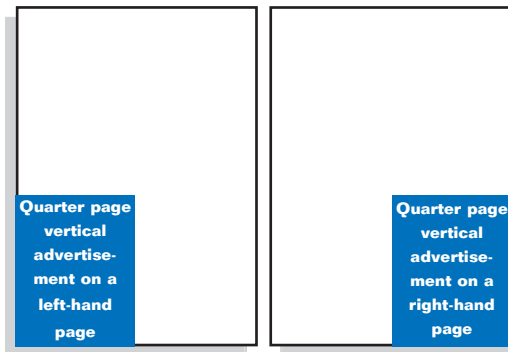

BROOKEPATTRICK
P U B L I C A T I O N S

Magazine advertisement

Quarter page

VERTICAL

297 mm x 100 mm

Booking Deadline

1st day of the month prior to the month of publication.

Material Deadline

5th day of the month prior to the month of publication.

Bleed advertisement

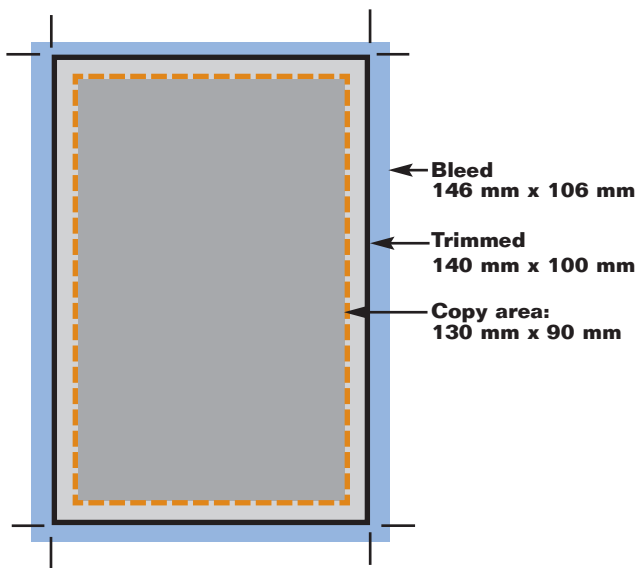

“Floating” advertisement

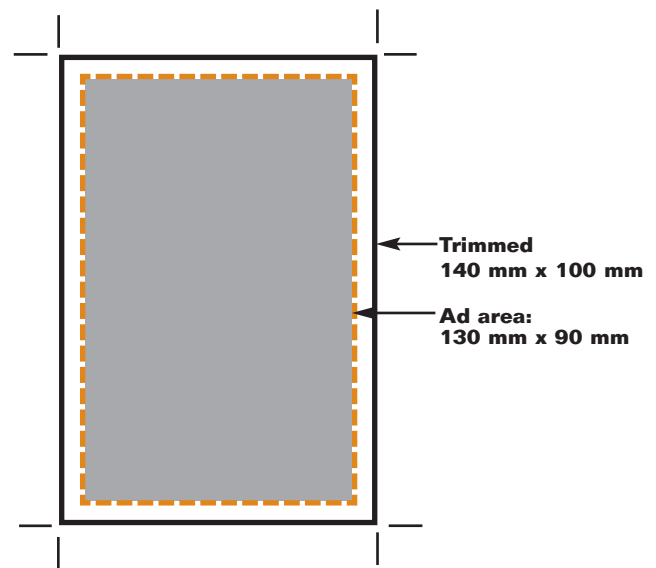

Reproduction material

- **Digital files required** - **PDF** (Closed, all fonts included, press-optimised PDF file, PDF/X-1a:2001)
 - **Tiff** (300 dpi Tiff (CMYK, real advertisement size)
 - **JPG** (300 dpi JPG, highest quality (CMYK, real advertisement size)

Brooke Patrick Publications can ONLY accept these three file types.

- **Crop marks**

All digital files must be supplied with crop marks. Crop marks must show the trim size.

A conversion rate of R350 will be applicable if the advertisements must be re-sized or are supplied without crop marks.

- **Bleed**

All files must have 3 mm bleed.

- **Colour proof**

A colour proof of the advertisement must be submitted. Brooke Patrick Publications accepts no responsibility for colour variations in advertisements that are supplied without a colour correct proof.

Advertisement specifications

- Files can be supplied on **CD, DVD, websend** or via **e-mail** (e-mail file not exceeding 8 MB).
- Advertisements can be e-mailed to **ntp@brookepatrick.co.za**

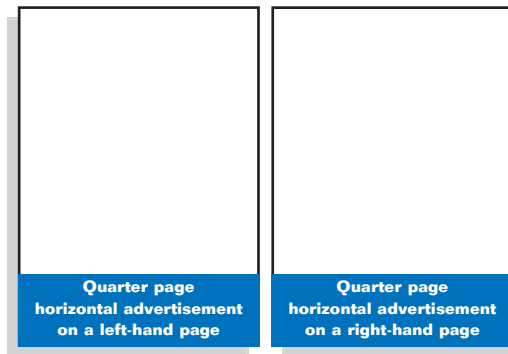

BROOKE PATTRICK
P U B L I C A T I O N S

Magazine advertisement

Quarter Page

HORIZONTAL

70 mm x 210 mm

Booking Deadline

1st day of the month prior to the month of publication.

Material Deadline

5th day of the month prior to the month of publication.

Bleed advertisement

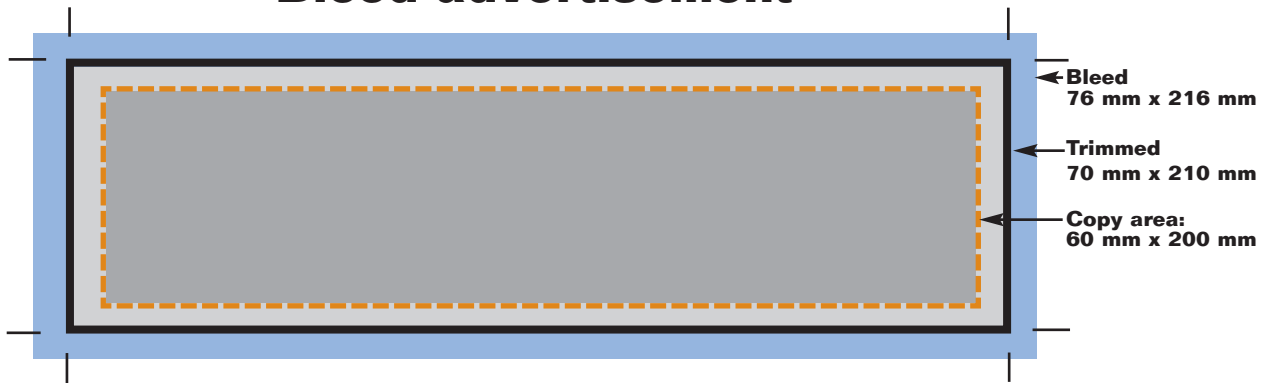

“Floating” advertisement



Reproduction material

- **Digital files required** - **PDF** (Closed, all fonts included, press-optimised PDF file, PDF/X-1a:2001)
 - **Tiff** (300 dpi Tiff (CMYK, real advertisement size)
 - **JPG** (300 dpi JPG, highest quality (CMYK, real advertisement size)

Brooke Patrick Publications can ONLY accept these three file types.

- **Crop marks**

All digital files must be supplied with crop marks. Crop marks must show the trim size.

A conversion rate of R350 will be applicable if the advertisements must be re-sized or are supplied without crop marks.

- **Bleed**

All files must have 3 mm bleed.

- **Colour proof**

A colour proof of the advertisement must be submitted. Brooke Patrick Publications accepts no responsibility for colour variations in advertisements that are supplied without a colour correct proof.

Advertisement specifications

- Files can be supplied on **CD, DVD, websend** or via **e-mail** (e-mail file not exceeding 8 MB).
- Advertisements can be e-mailed to **ntp@brookepatrick.co.za**

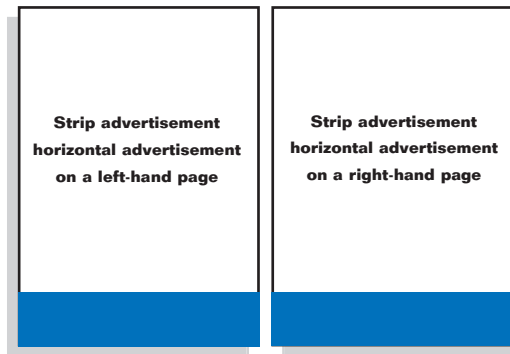

Magazine advertisement

Strip

HORIZONTAL

55 mm x 210 mm

Booking Deadline

1st day of the month prior to the month of publication.

Material Deadline

5th day of the month prior to the month of publication.

BROOKEPATTRICK
P U B L I C A T I O N S

Bleed advertisement

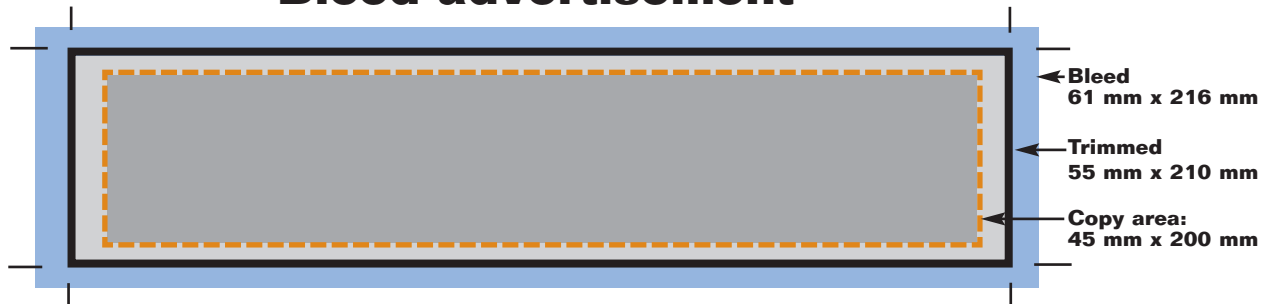

“Floating” advertisement



Reproduction material

- **Digital files required** - **PDF** (Closed, all fonts included, press-optimised PDF file, PDF/X-1a:2001)
 - **Tiff** (300 dpi Tiff (CMYK, real advertisement size)
 - **JPG** (300 dpi JPG, highest quality (CMYK, real advertisement size)

Brooke Patrick Publications can ONLY accept these three file types.

- **Crop marks**

All digital files must be supplied with crop marks. Crop marks must show the trim size.

A conversion rate of R350 will be applicable if the advertisements must be re-sized or are supplied without crop marks.

- **Bleed**

All files must have 3 mm bleed.

- **Colour proof**

A colour proof of the advertisement must be submitted. Brooke Patrick Publications accepts no responsibility for colour variations in advertisements that are supplied without a colour correct proof.

Directory advertisement sizes

Size A

56 mm x 48 mm

Size C

56 mm x 144 mm

Size D

56 mm x 192 mm

Size B

56 mm x 96 mm

Reproduction material

- **Digital files required** - **PDF** (Closed, all fonts included, press-optimised PDF file, PDF/X-1a:2001)
 - **Tiff** (300 dpi Tiff (CMYK, real advertisement size)
 - **JPG** (300 dpi JPG, highest quality (CMYK, real advertisement size)

Brooke Patrick Publications can ONLY accept these three file types.

- **Crop marks**

All digital files must be supplied with crop marks. Crop marks must show the trim size.

A conversion rate of R350 will be applicable if the advertisements must be re-sized or are supplied without crop marks.

- **Colour proof**

A colour proof of the advertisement must be submitted. Brooke Patrick Publications accepts no responsibility for colour variations in advertisements that are supplied without a colour correct proof.

Advertisement specifications

- Files can be supplied on **CD, DVD, websend** or via **e-mail** (e-mail file not exceeding 8 MB).
- Advertisements can be e-mailed to **dtp@brookepatrick.co.za**

Bulletin advertisement

Banner

HORIZONTAL

72 dpi

Booking Deadline

1st day of the month prior to the month of publication.

Material Deadline

5th day of the month prior to the month of publication.

BROOKEPATTRICK
P U B L I C A T I O N S

- **Size**

484 x 85 pixels at 72 dpi
(170.7 mm x 30 mm at 72 dpi)
RGB or index colour

Reproduction material

- **Digital files required** - **Gif** (can be an animated Gif file)
- **JPG**

Brooke Patrick Publications ONLY accepts these two file types.

- **Size**

484 x 85 pixels at 72 dpi

- **File size**

Less than 120 kB

- **DPI**

72 dpi

- **Colour**

RGB or index colour

Example of an A4 advertisement with bleed

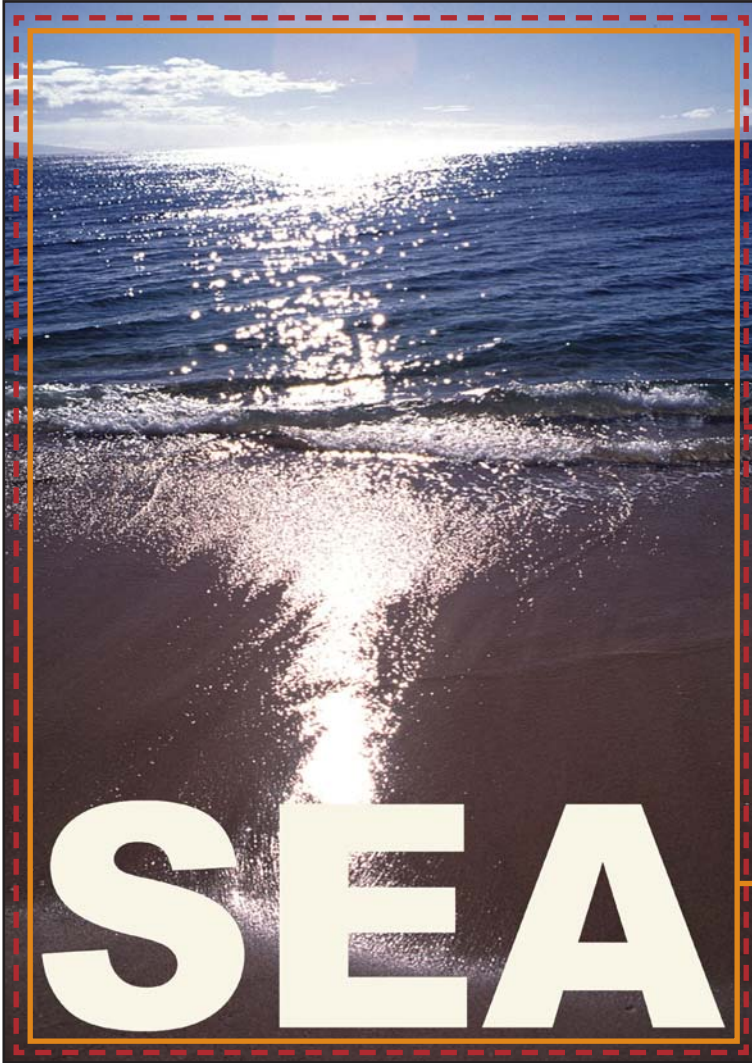

Bleed advertisement

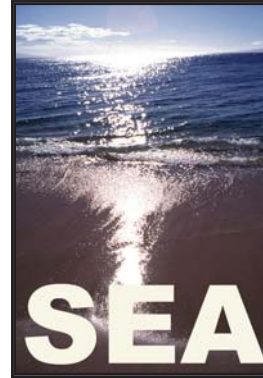

Floating advertisement

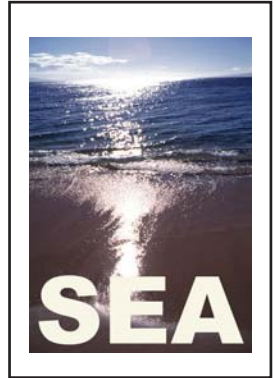

Trimmed size/Booked size

This is the actual size of the advertisement as it will appear in the magazine. In this case it, is an A4, 297 mm x 210 mm.

Bleed

If your advertisement fills the advertisement space in full, and does not have white space around it, it is an advertisement with bleed. All bleed ads MUST have 3 mm of bleed surrounding the advertisement. This bleed is necessary so that, when magazines are trimmed, your advertisement "bleeds" (flows) off the page.

Advertisement copy area

Copy should not go outside this space. The copy area must be at least 5 mm inside the trim area. If you place copy outside this area, you run the risk of the copy being trimmed off when the magazines are cut.

Copy too close to the cutting edge

There is a strong chance that the printer may trim your copy.

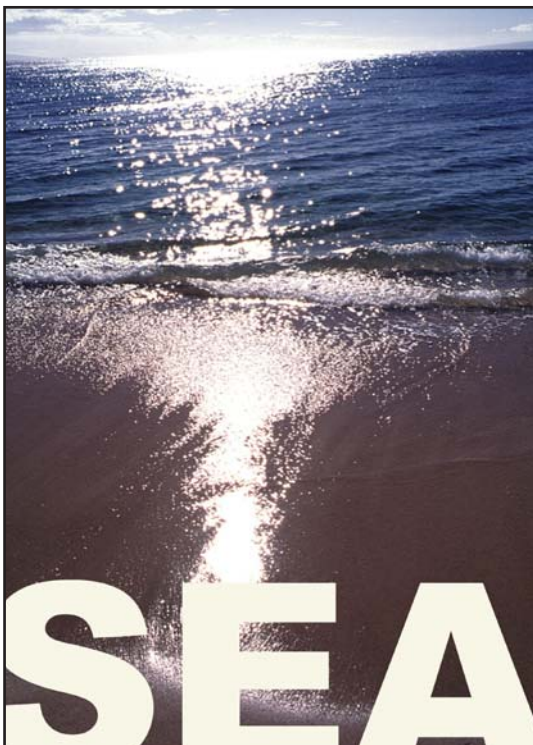

Not enough bleed

You will get "white space" on your ad; the colour will not flow off the page.

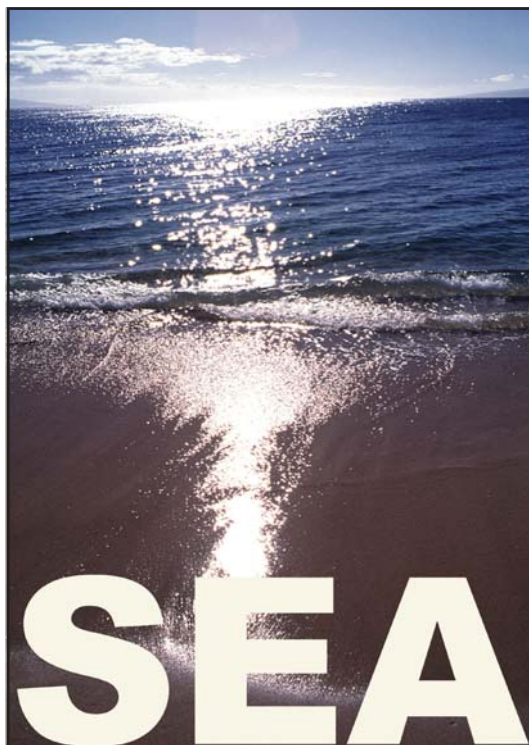

Example of an A4 advertisement without bleed (“floating” advertisement)

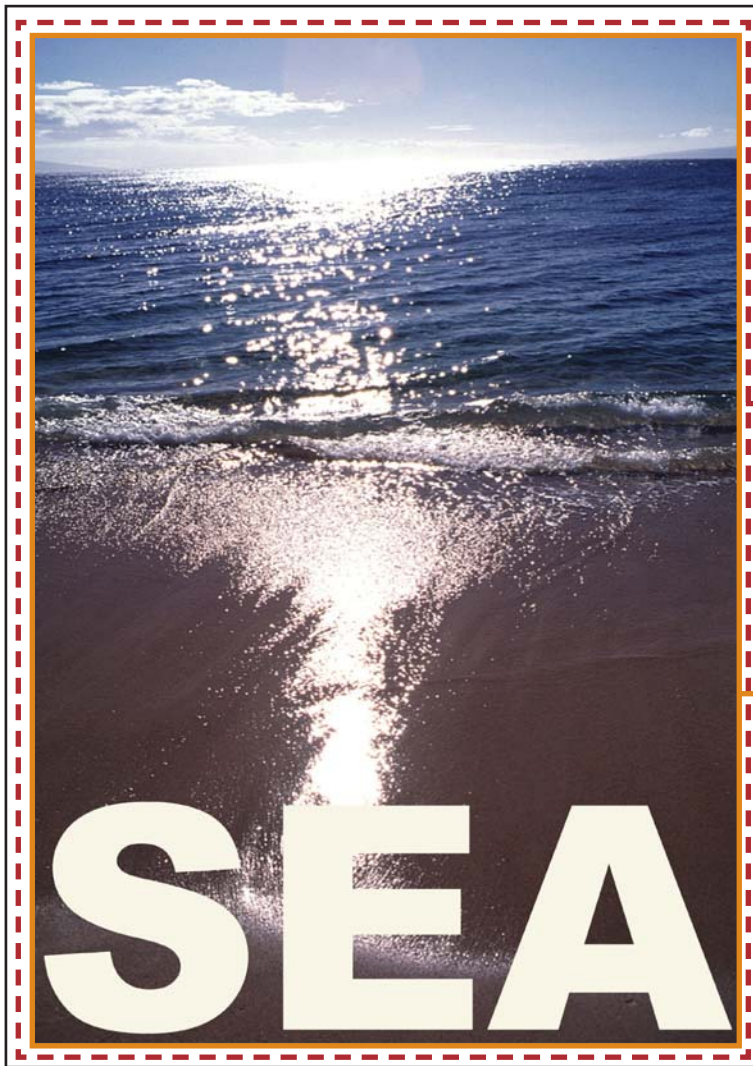

Trimmed size/Booked size

This is the actual size of the advertisement as it will appear in the magazine. In this case, it is an A4, 297 mm x 21 mm.

Bleed

A floating advertisement does not have bleed. There is white space of 5 mm between the advertisement and the trim edge.

Advertisement copy area

Copy should not go outside this space. The copy area must be at least 5 mm inside the trim area. If you place copy outside this area, you run the risk of the copy being trimmed off when the magazines are cut.

A low-res advertisement (bitmapping)

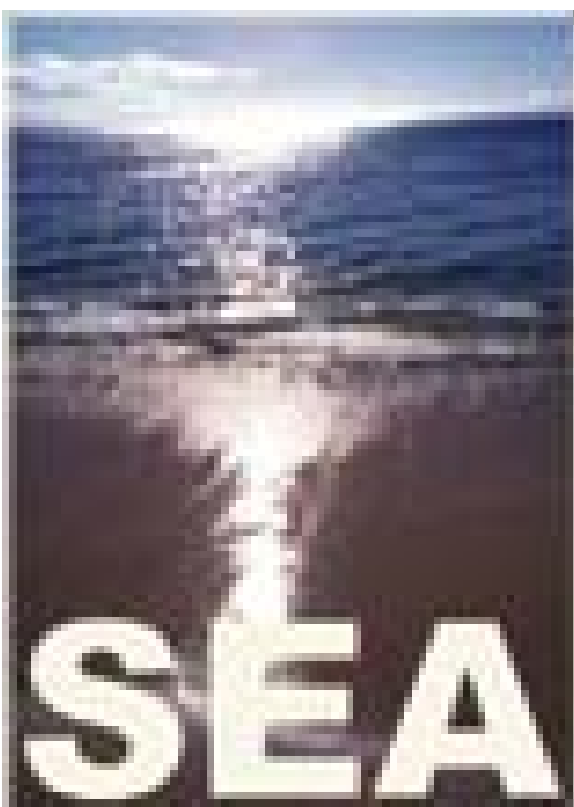

Colour example

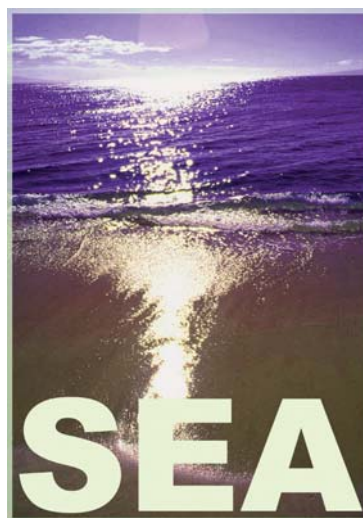

RGB

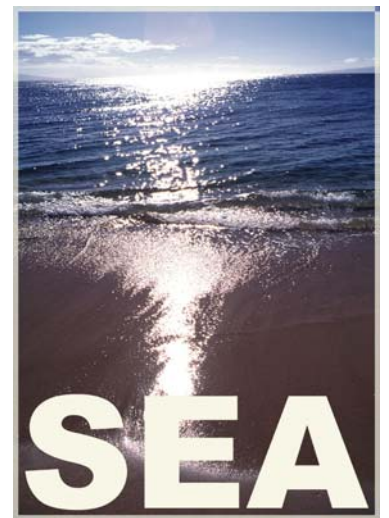

CMYK

We print in CMYK. Most desktop printers print in RGB colour scheme, and the print-out you see is not a true reflection of the advertisement printed in CMYK. The only way to check the colour of your advertisement is to ask your agency for a chromalin.

- A colour proof of the advertisement must be submitted.

Facts & Rates 2009

Brooke Patrick Publications Studio

has the capability and capacity to design any graphic work for use in printed media.

- **Advertisement make-up**
- **All stationery needs**
 Letterheads
 Compliment slips
 Business cards
- **Annual reports**
- **Sustainability reports**
- **Brochures**
- **Logo design**

The five-strong Brooke Patrick Publications Studio creative team is headed by Christelle Jordaan who has a degree in graphic design.

The goal of the studio is to help clients of Brooke Patrick Publications meet all their graphic design needs at reasonable cost.

Brooke Patrick Publications Studio produces exceptional graphic work while containing costs within the Brooke Patrick Publications group.

Brooke Patrick Publications Studio also has a vested interest in ensuring that its work is of the quality one would expect from a Brooke Patrick Publications magazine. This ensures that your message will fetch the desired results when used consistently and in the correct medium.

Make-up of advertisement material

All make-up of new advertisements or alterations to existing advertisements will be charged according to the scale listed below.

DPS Includes two logo placements, 5 scans and typesetting	R1 990
Full page Includes two logo placements, 4 scans and typesetting	R1 600
Half page Includes one logo placement, 3 scans and typesetting	R1 300
Third page Includes one logo placement, 3 scans and typesetting	R1 200
Quarter page Includes one logo placement, 2 scans and typesetting	R990
Strip Includes one logo placement, 2 scans and typesetting	R850
Digital banner advertisement Includes one logo placement, 2 scans and typesetting	R850
Directory listing Includes one logo placement and typesetting	R790

The above make-up cost includes 2 proofs and a client copy of the material on disc. Any extra changes will be charged as author corrections at an additional hourly rate of R350.

Purchasing photos

Photographs taken by Brooke Patrick Publications may also be purchased.

This is structured in two tiers.

For once off use and third-party repurchases	R600
For total photographic ownership and exclusivity	R2 300

Other charges

Extra pictures scanned:	R140	per picture
Chromalin:	R520	A4 or smaller
Any other additional studio work:	R350	per hour
Minimum of R250 will be charged for changing addresses and/or contact details on ads that Imibala Studio created		
Basic administration costs will be charged at R350 for cancellations after approval.		

Christelle Jordaan
 Manager: Graphics and Production
 Tel: +27 11 603-3960, E-mail: cjordaan@brookepatrick.co.za

Brooke Patrick Publications (Pty) Ltd

Building #13, Pinewood Office Park,
 33 Riley Road, Woodmead
 Private Bag X40, Rivonia, 2128, South Africa